

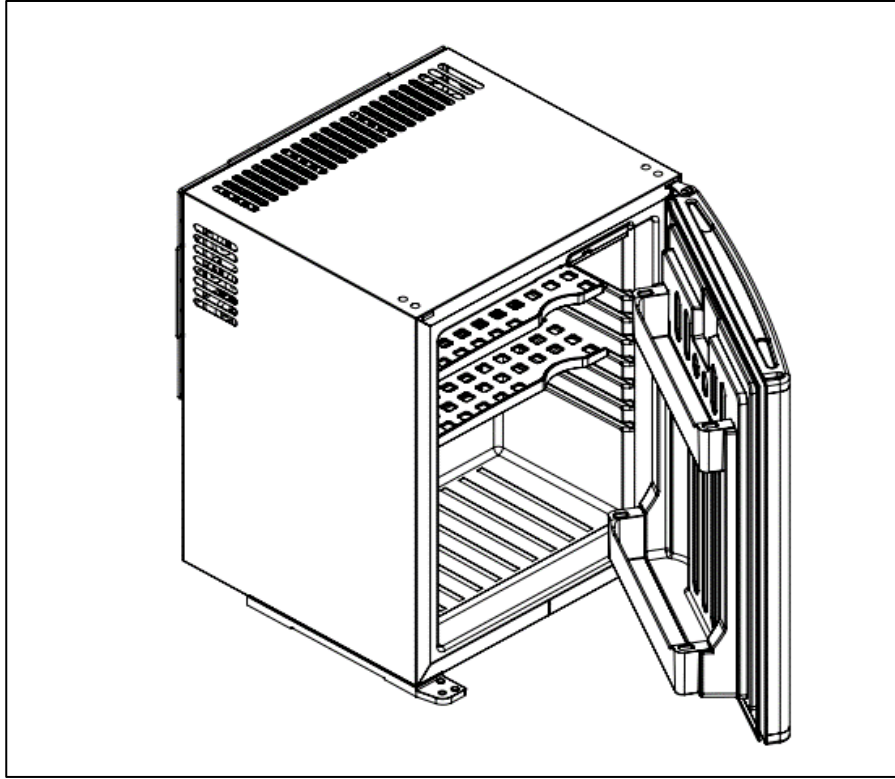

Bädd & Bad AB
Grustagsgatan 22
254 64 Helsingborg, Sweden
Tel. +46 42 26 66 60

Revizyon no / Revision no : 03
Revizyon tarihi / Revision date : 30.01.2024
Model: SM 301-TH MINIBAR

TECHNICAL SPECIFICATIONS



MODEL: 81914460

TECHNICAL DATA SHEET

CHARACTERISTICS

➤ Compartment Type	: Cellar/ Killer
➤ Energy Efficient Class	: G
➤ Climate Class	: N
➤ Energy Consump.	: 108 (KWh per year)
➤ Energy Efficiency Index	: 140 %
➤ Power	: 50 W
➤ Voltage / Freq.	: 110 V - 240 V / 50-60 Hz.
➤ Defrosting Type	: Automatic
➤ Noise Emission	: 23 (dB(A) re 1 pW)

ACCESSORIES

➤ Internal Light	: Standart
➤ Lockable Door	: Opsiyonel
➤ Door Hinge Side	: Sağ/Right
➤ Reversible Door	: Yes
➤ Thermostat Control	: Electronic

TECHNICAL SPECIFICATIONS

➤ External Dims.	: 512x420x395 mm (HxWxD)
➤ Internal Dims.	: 421x355x188 mm (HxWxD)
➤ Pack. Dims.	: 559x432x464 (HxWxD)
➤ Pack. Volume	: 0,11 m ³
➤ Total Volume	: 27 lt
➤ Gross Volume	: 30 lt
➤ Gross Weight	: (11,2 ±1) kg
➤ Net Weight	: (9,95 ±1) kg
➤ Outer Body	: 0.4 mm.PVC Kaplı Sac / 0,4 PVC Cooted Sheet
➤ Inner Liner	: Hips
➤ Insulation Material	: Sert P.U. / Rigid P.U.
➤ Blowing Agent	: C.Pentane
➤ Insulation Density	: 38~40 kg/m ³